

Vibration Test System TV 51075

DESCRIPTION

TIRA permanent magnet shakers are applicable as portable and stationary systems for reproducing environmental effects.

Typical fields of applications are modal excitation and analyses, structural testing, calibration of sensors and testing of small components. The rugged design of the shakers guarantees their long operating life. TIRA shakers stand for such features like a high lateral and axial stiffness.

TIRA have realized the light-weight design of shakers required by the industry. New rare-earth magnets replace the alnico magnets used up to now. Thus, a weight reduction from 30 kg (66 lb) to 10 kg (22 lb) could be achieved which enables an easy shaker-handling especially for mobile applications as "one man" excitation source.

These shakers have turned out to be outstanding in fields of applications such as environmental laboratories, universities and industrial production lines for testing components and for in-house calibration. This line of shakers enables the user to carry out tests in accordance with national and international standards such as DIN, ISO, BS, MIL, IEC ...



AMPLIFIER BAA 120

KVA ratings	120 VA
Frequency range	DC-20 kHz
Voltage, max.	22 V
Current, max.	5.5 A
Load resistance	4 Ohm
Input voltage	< 5 V
Distortion	<0.1 %
Signal to noise ratio	> 90 dB
Weight	16 kg (35.3 lb)
Size (WxHxD)	483 x 90 x 450 mm (19 x 3.5 x 17.7 in)



TECHNICAL SPECIFICATION VIBRATION GENERATOR S 51075

Rated peak force (N lbf)	Sine/Random	75/40	16/8
Frequency range (Hz)		2-7000	2-7000
Max. rated travel (mm inch)	Pk-Pk	10	0.39
Max. velocity (m/sec inch/sec)	Sine/Random	1.5/1.5	59/59
Max. acceleration (g)	Sine/Random	50/30	50/30
Max. power consumption at 230 V (kVA)		0.07	0.07
Nominal impedance (Ohm)		4	4
Suspension stiffness (N/mm lbf/inch)		6.5	37.1
Effective moving mass (kg lb)		0.15	0.331
Main resonance frequency (Hz)		> 5500	> 5500
Weight with trunnion (kg lb)		20	44.1
Armature (ø/mm ø/inch)		40	1.57

PERFORMANCE DIAGRAM

System Performance TV 51075

Force: 75 N max. Acceleration: 50 g max. Velocity: 1,5 m/s max. Displacement: 10 mm

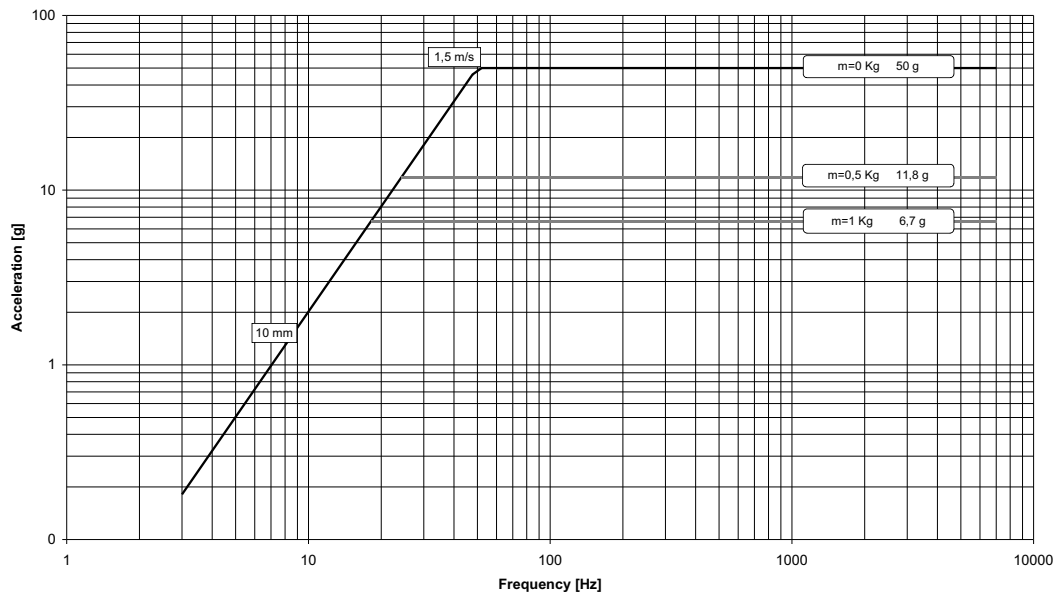

DIMENSIONS in mm

S 51075 (Example drawing)

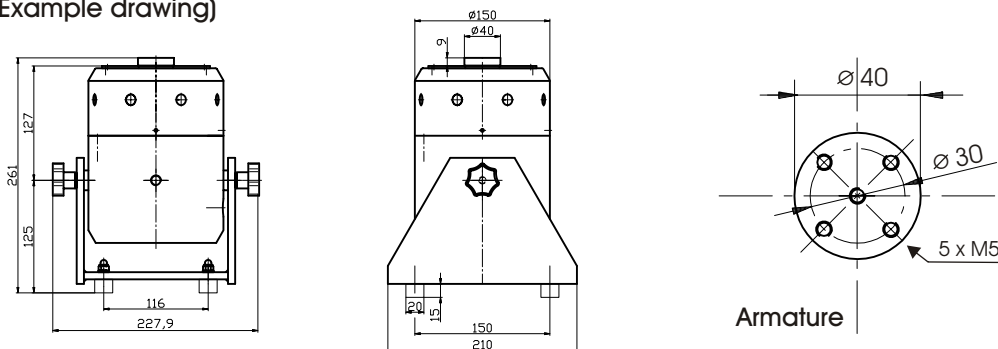

Subject to modifications