

Vibration Test System TV 51120 - C



DESCRIPTION

In all fields of industry, in aviation, the automotive industry and in power stations vibration analyses and measurements for determining the vibration transmission are increasingly carried out.

A large variety of measuring sensors are necessary to realize such investigations. These measuring sensors have to be checked for their accuracy and calibration in defined time intervals.

As most of the measuring sensors have a large measuring range and large frequency ranges, special shakers for calibrating these sensors are required.

TIRA has risen to this challenge and designed a unique shaker which meets these requirements. This newly developed shaker is equipped with a special guide system and a vibration system made of ceramic material. It is characterised by a very high utilisable frequency range up to 25 kHz and with the appropriate measuring equipment it is optimally suitable for professional calibration applications.

AMPLIFIER BAA 500

KVA ratings	500 VA
Frequency range	DC - 20 kHz
Voltage, max.	45 V
Current, max.	11.2 A
Load resistance	4 Ohm
Input voltage	< 5 V
Distortion	< 0.1 %
Signal to noise ratio	> 90 dB
Weight	25 kg (55.1 lb)
Size (WxHxD)	483 x 90 x 450 mm (19 x 3.5 x 17.7 in)



TECHNICAL SPECIFICATION VIBRATION GENERATOR S 51120-C

Rated peak force (N lbf)	Sine/Random	200/100	45/22
Frequency range (Hz)		40-25000	40-25000
Max. rated travel (mm inch)	Pk-Pk	4	0.2
Max. velocity (m/sec inch/sec)	Sine/Random	1.2/1.2	47/47
Max. acceleration (g)	Sine/Random	51/25	51/25
Max. power consumption at 230 V (kVA)		0.35	0.35
Nominal impedance (Ohm)		4	4
Effective moving mass (kg lb)		0.40	0.88
Main resonance frequency (Hz)		> 25000	> 25000
Weight with trunnion (kg lb)		42	92.6
Armature (ø/mm ø/inch)		54	2.1
Cooling (m³/h ft³/min)		40	24

PERFORMANCE DIAGRAM

System Performance TV 51120-C

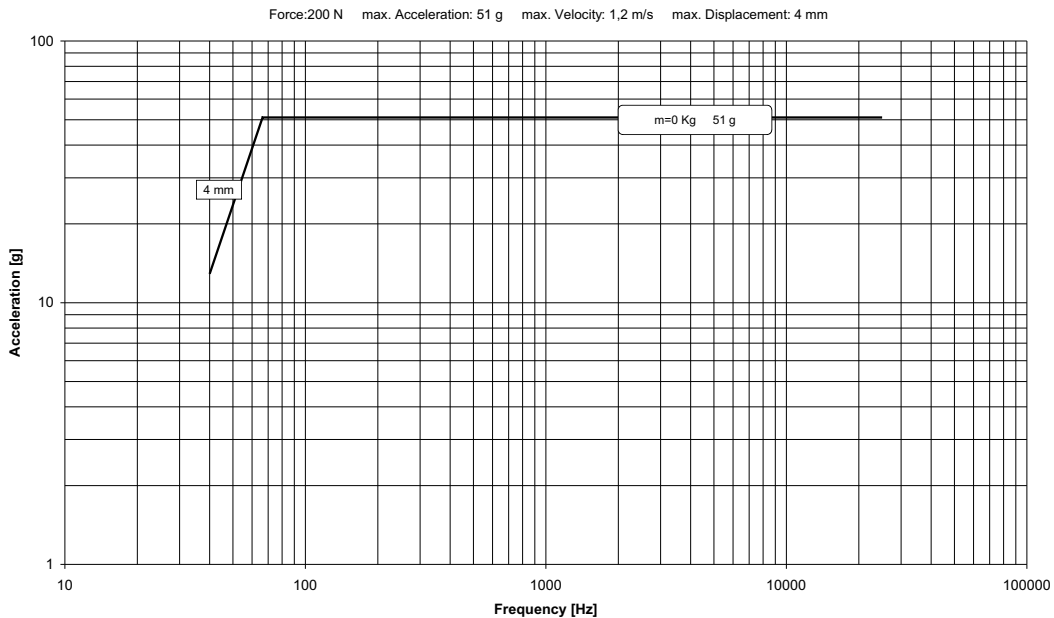

DIMENSIONS in mm

S 51120-C (Example drawing)

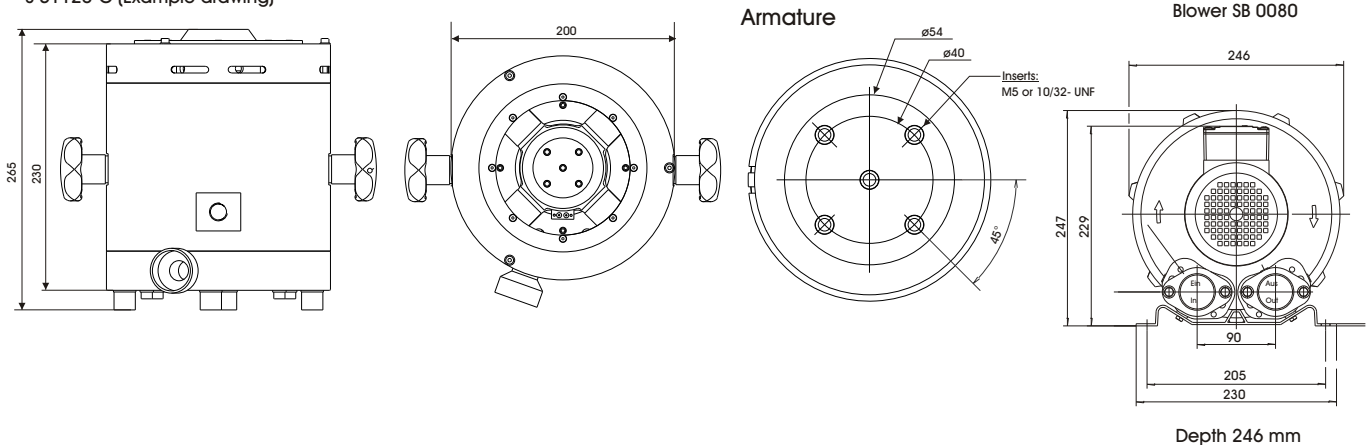

Subject to modifications