

# Vibration Test System TV 56280/LSS-250



## DESCRIPTION

Longstroke Shaker with 102 mm displacement

Due to the ever increasing safety requirements the industry develops more and more sensor technology and components that have to be tested under extreme stress conditions.

The test parameters are developing up to higher and higher accelerations in combinations with large impact ranges. These tests cannot be realized with conventional standard systems with an amplitude of 50.8 mm (2 inch).

TIRA has met the requirements of the industry to manufacture test installations that can imitate extreme shock simulations. It developed a series of long-stroke shakers with an amplitude of 102 mm (4 inch, peak to peak).

Apart from their application in laboratories for testing development problems the integration of these shakers in complete production lines has optimally proved.

## AMPLIFIER A 1 02 1 015 T

KVA ratings	16000 VA
Frequency range	DC - 4 kHz
Voltage, max.	105 V
Current, max.	150 A
Load resistance	1 Ohm
Input voltage	2.5/5/10 V
Distortion	< 0.7 %
Signal to noise ratio	> 90 dB
Field voltage, max.	280 V
Field current, max.	6 A
Weight	360 kg (793.7 lb)
Size (WxHxD)	600 x 1800 x 800 mm (23.6 x 70.9 x 31.5 in)

# TECHNICAL SPECIFICATION VIBRATION GENERATOR S 56280/LSS-250

Rated peak force (N   lbf)	Sine/Random/Shock	8000/8000/16000	1800/1800/3600
Frequency range (Hz)		DC-2000	DC-2000
Max. rated travel (mm   inch)	Pk-Pk	102	4.0
	Overtravel	107	4.21
	Mechanical Stop	112	4.41
Max. velocity (m/sec   inch/sec)	Sine/Random/Shock	3.0/3.0/4.5	118/118/177
Max. acceleration (g)	Sine/Random/Shock	68/68/136	68/68/136
Max. power consumption at 400 V (kVA)		14	14
Suspension stiffness	Electronically adjustable		
Effective moving mass (kg   lb)		12.0	26.5
Main resonance frequency (Hz)		>2000	>2000
Weight with trunnion (kg   lb)		1000	2205
Armature (ø/mm   ø/inch)		250	9.8
Cooling (m <sup>3</sup> /h   ft <sup>3</sup> /min)		500	294

## PERFORMANCE DIAGRAM

### System Performance TV 56280/LSS-250

Force: 8000 N max. Acceleration: 68 g max. Velocity: 3,0 m/s max. Displacement: 102 mm

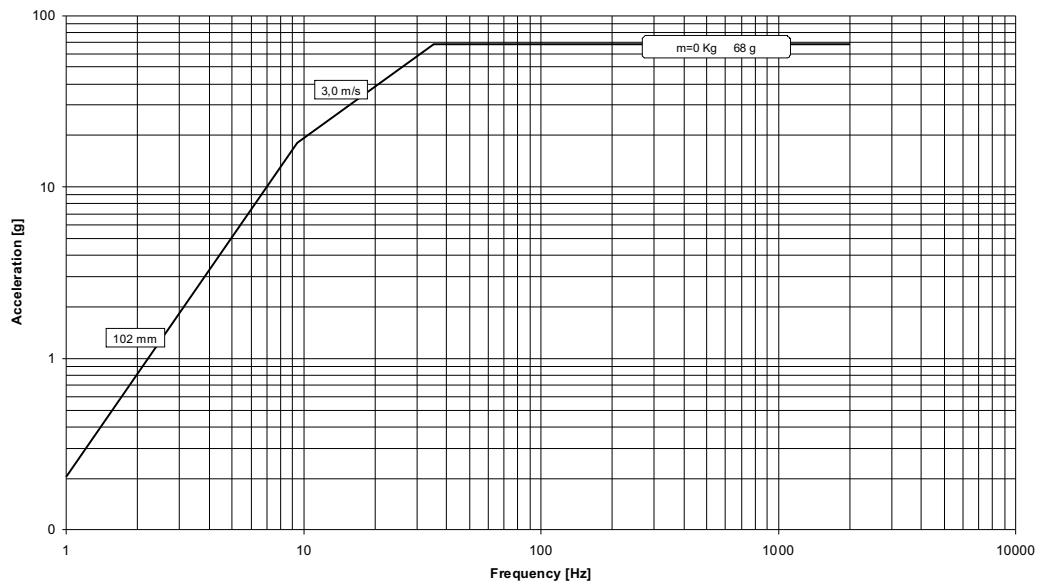

## DIMENSIONS ( mm )

S 56280/LSS-250 (Example drawing)

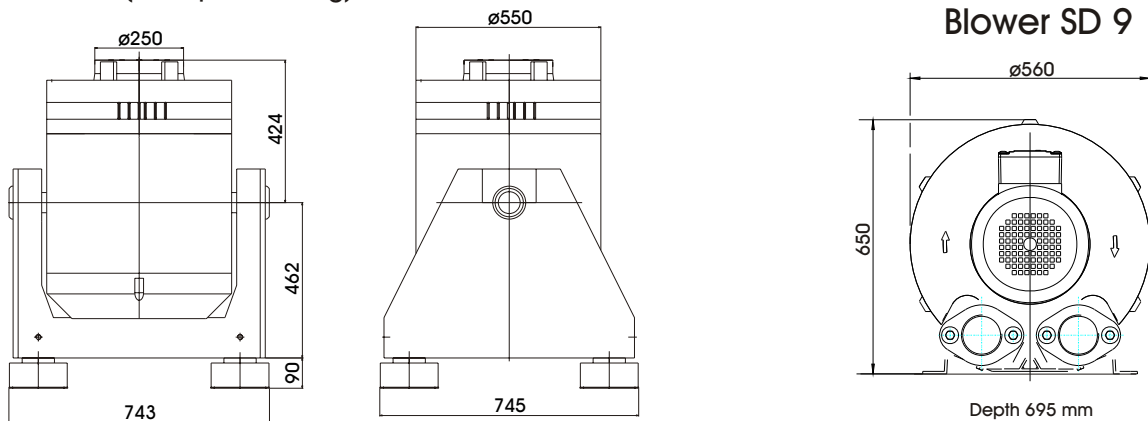

Subject to modifications